



Austune Commercial Pty Ltd
 Unit 1, 79-85 Mars Road
 Lane Cove West NSW 2066
 Tel: (02) 9420 4477
 www.austunecommercial.com

SALAD TABLE - HOOD LID REFRIGERATOR
MODEL : KHR18-3



- Pans included.

FEATURES / BENEFITS

CONVENIENT CUTTING BOARD SIDE RAIL

Our cutting board is 240mm deep and 12mm thick to provide ample working space, and is made of easy to use and sanitize LDPE (Low Density Polyethylene). The new side rail cutting board bracket makes it easy to secure and remove the cutting board and it accepts different sizes too (max. 12mm thickness)

HOT GAS CONDENSATE SYSTEM

Through Turbo Air's creative innovation, the condensate system surfaces have been specially treated to resist corrosion. This not only increases efficiency without the risk of refrigerant leakage from corrosion, but also prevents the overflow of condensate water.

SIDE MOUNT COMPRESSOR UNIT

By positioning the compressor on the side of the unit, refrigerators can now be serviced without being moved.

COLD AIR CURTAIN SYSTEM

Our innovative forced air system allows cold air to flow all around the food pan area, covering not only underneath the pan, but also to the front, top and the rear.

ERGONOMICALLY DESIGNED DOORS

Customers' fatigue fades away with easy grip handles and doors that open effortlessly. These features along with self-closing doors make this the ultimate choice in customer convenience.

EFFICIENT REFRIGERATION SYSTEM

Turbo Air's solid door refrigerators are designed with oversized and balanced refrigeration systems. These include efficient evaporators and condensers for faster cooling and greater efficiency.

EXTERIOR & INTERIOR OF THE CABINET

The Turbo Air K series boasts a stainless steel exterior (galvanized steel back and bottom). Interior is stainless steel floor with AL sides, back and AL door liners. It guarantees the utmost in cleanliness and long product life. It can add a touch of style to the most refined setting.

HIGH-DENSITY POLYURETHANE INSULATION

The entire cabinet structure and solid doors are foamed-in-place using high density, CFC free polyurethane insulation.

MAGNETIC DOOR GASKETS

Magnetic door gaskets are of one piece construction, removable without tools for ease of cleaning and replacement.

ADJUSTABLE, HEAVY DUTY, PE(POLYETHYLENE) COATED WIRE SHELVES

Model	Swing Door	Capacity (litres)	#of Shelves	HP	AMPS	Crated Weight (kg)	W x D x H (mm)
KHR18-3	3	516	3	1/3	3.0	120	1800 x 700 x 1028

Ver.DEC.2015



SALAD TABLE - HOOD LID

REFRIGERATOR
MODEL : KHR18-3

Model : KHR18-3

SPEC SHEET	KHR18-3
Classification	Refrigerator
Cabinet dimension (WxDxH mm)	1800x700x1028
Capacity (Liters)	516
Inner Temperature	1°C ~ 8°C
Ambient Temperature	40°C
Doors	3
# of shelves	3
Refrigerant	R-134a
Compressor (HP)	1/3
Cooling Type	Fan cooling type
Insulation Type	Polyurethane/ Cyclopentane+CFC Free
Temperature Control Type	Digital
Amps (A)	3.0
Voltage (V/Hz/Ph)	240V 50Hz 1Ph
Power (W)	366
Weight (Kg)	120

Design and specifications subject to change without notice.
Actual shipping weight may differ due to extra packing materials for product protection.

- DOOR LOCKS STANDARD
- SELF-CONTAINED SYSTEM
- STANDARD 4" SWIVEL CASTERS WITH LOCKS ON THE FRONT SET
- STANDARD 1/6 SIZE, 100MM DEEP CONDIMENT PANS INCLUDED
- 240MM DEEP, 12MM THICK CUTTING BOARD INCLUDED

WARRANTY **2 YEARS**
PARTS & LABOUR

Ver.DEC.2015

PLAN VIEW

(unit : mm)

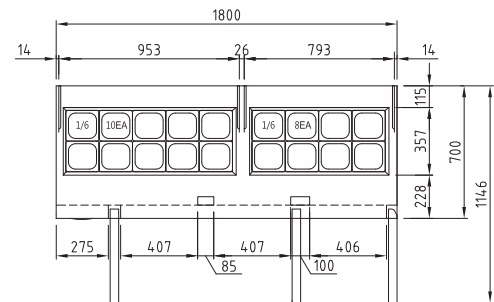

PLAN VIEW

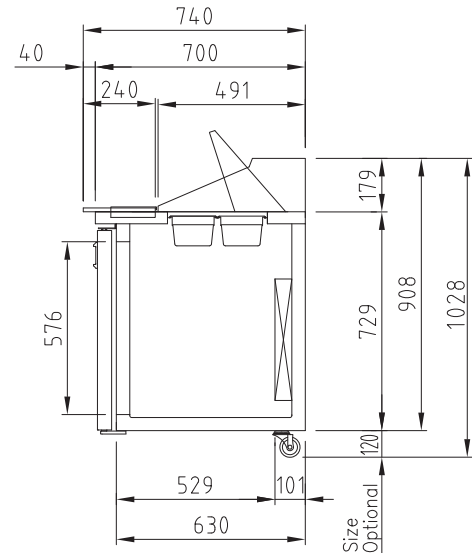

SIDE VIEW



Unit 1, 79-85 Mars Road, Lane Cove West NSW 2066
Tel: (02) 9420 4477
www.austunecommercial.com

REFRIGERATOR MANUFACTURER
Turbo air

Austune
1800 FRIDGE

